



F-20の作り方 Instruction

紙は、110-135kgがベストです。

 山折 mountain fold line

 カット線 cut line

 谷折 valley fold line

①. K:主翼の折り方

K Main Wing folding line

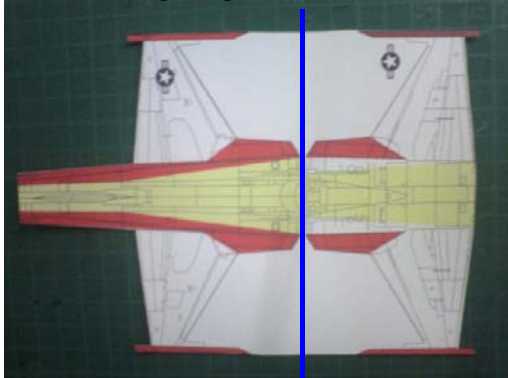

②. 主翼の上下を貼り合わせる

Fold and glue K Wing upper side and under side.

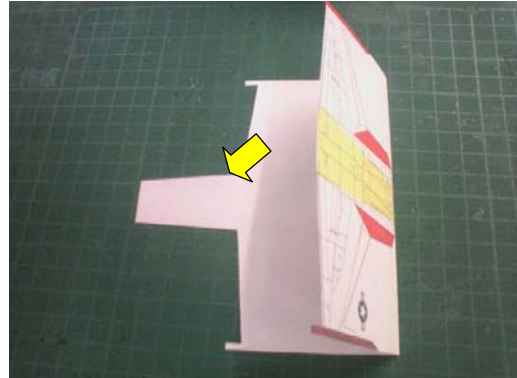

③. 余白を切り離す。

Cut apart white space

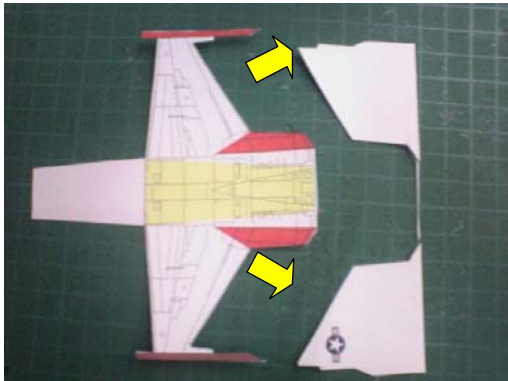

④. ノーズコーンの折り方

Folding line of nose corn.

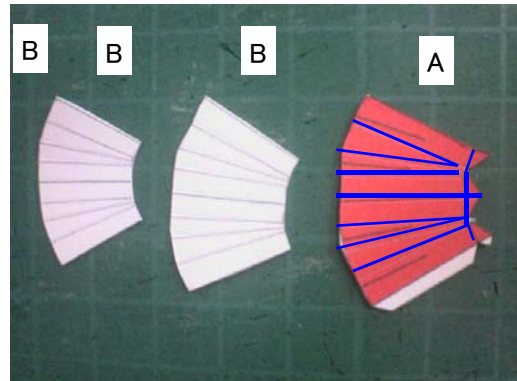

⑤. ノーズコーンにおもりを入れて接着

Fold and glue A nose corn and B weight 1s

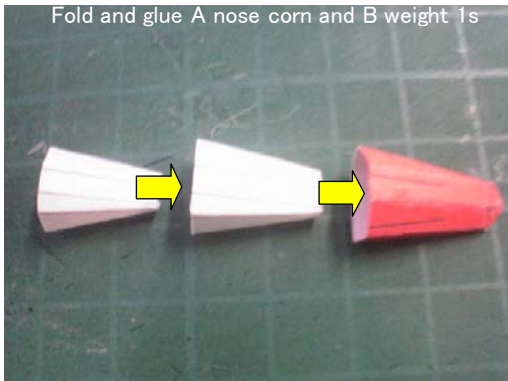

⑥. おもりが入ったノーズコーン

Figure of nose corn with weight 1s



⑦. 機首の折り方

Fold line of C: nose and D weight 2s

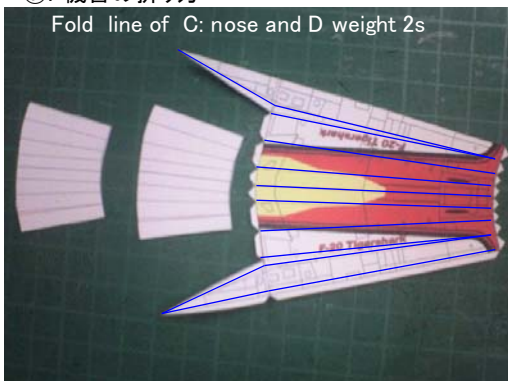

⑧. 折り目をつけた上におもりを接着する

Fold and glue together C: nose and D: weight 2s

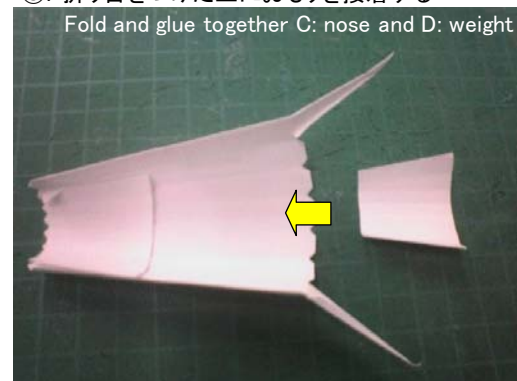

⑧. 機首を丸める。

Glue the C: nose bottom closed.

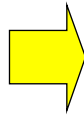
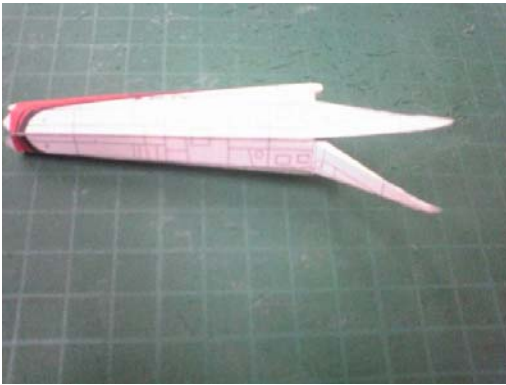

⑨. 機体の折り方。

Fold line of E: body upside

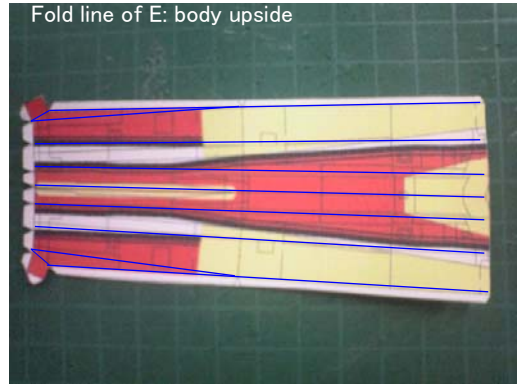

⑩. 機体を丸める。後ろを接着する。

Fold and glue only tail part

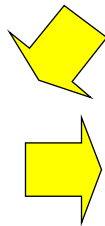
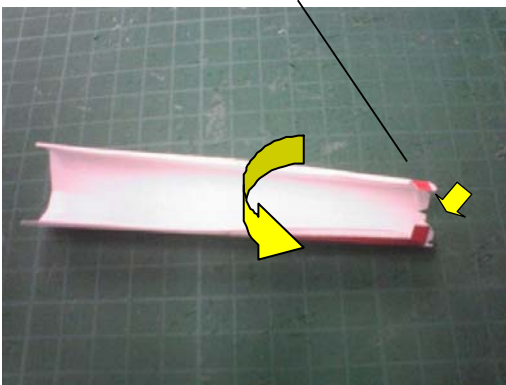

⑪. 機首と、機体をつける。

Glue together nose and body upside

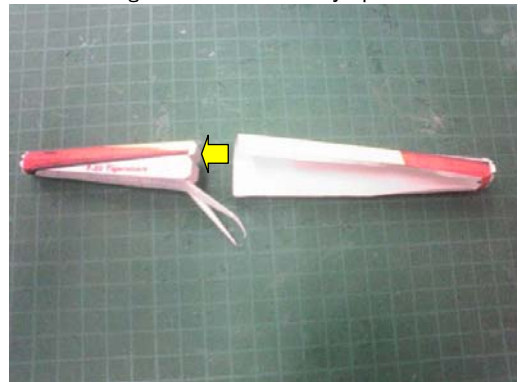

⑫. ノーズコーンをつける。

Glue together nose corn and body



⑬. キャノピーの作り方。

Figure canopy

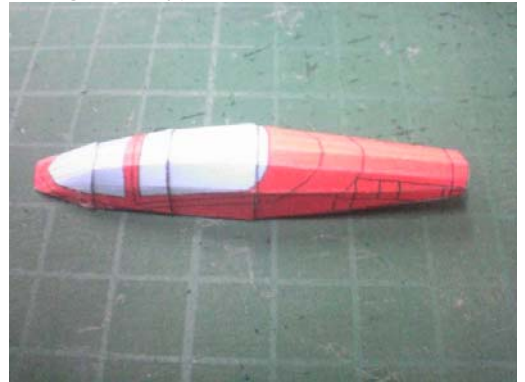

⑭. キャノピーを機体につける

Glue together canopy and body



⑮. エンジンノズルをつける。

Glue N: Engine nozzle closed and glue together body and engine nozzle.

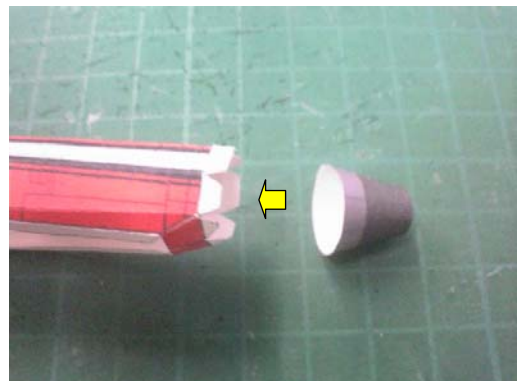

⑩. 機体下部の折り方。
Folding line of G body underside

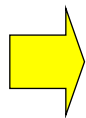
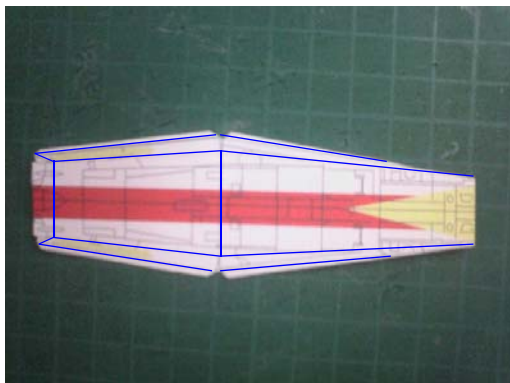

⑪. 機体下部の形つける。
Fold and glue the G body underside.

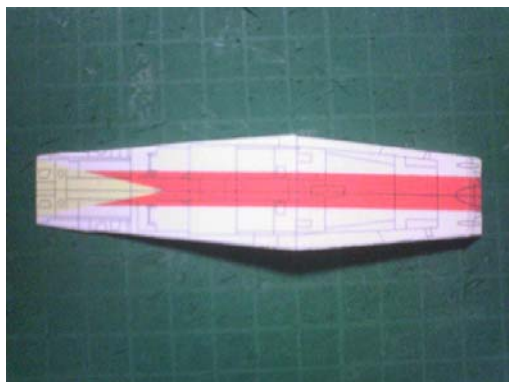

⑫. 機体下部を主翼につける。
glue G body underside to main wing

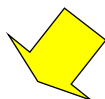
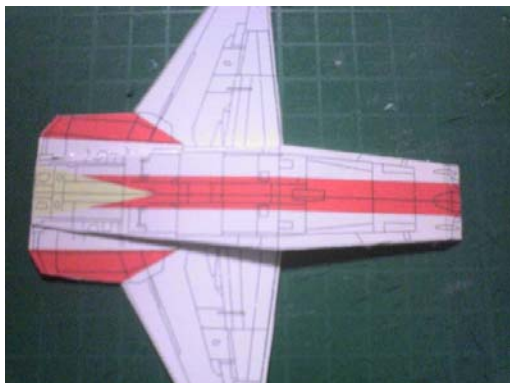

⑬. 機体を主翼につける。
Glue together body and main wing.



⑭. 機首の下の部分を閉じる。
Glue nose underside closed.

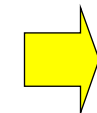
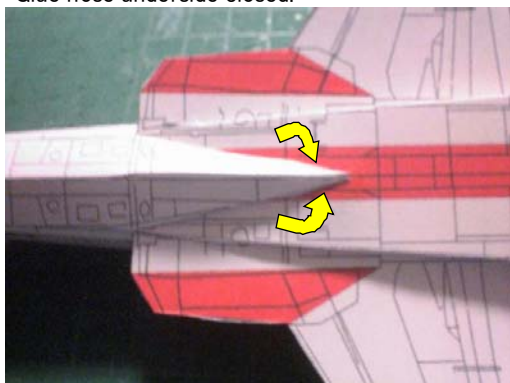

⑮. エアインテイクの折りかた。
Folding line and cutting line of L,M Air intake.

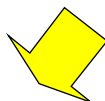
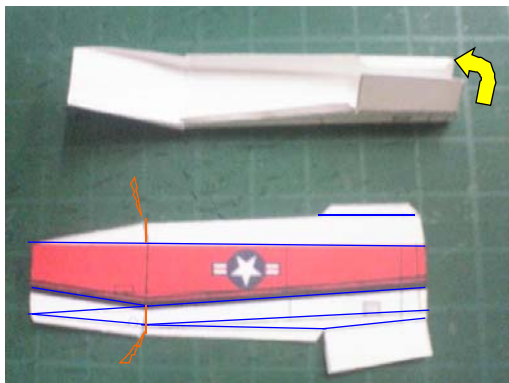

⑯. エアインテイクを組み立てる。
Fold and glue the Air intake closed.

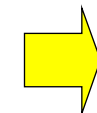

⑰. エアインテイクを機体につける。
Glue Air intake to body.

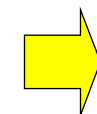
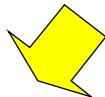

24. 垂直尾翼の折り方。
Folding line of rudder

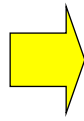
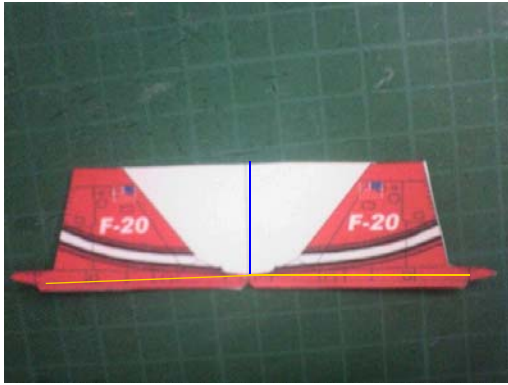

25. 垂直尾翼を組み立て、余分な部分をカットする。
Fold and glue the rudder and cut apart white space.

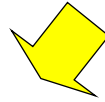

26. 垂直尾翼のを機体につける。
Glue rudder to body

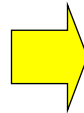

27. 水平尾翼の折り方と組み立て方
Folding line the J horizontal stabilizer

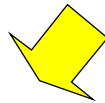
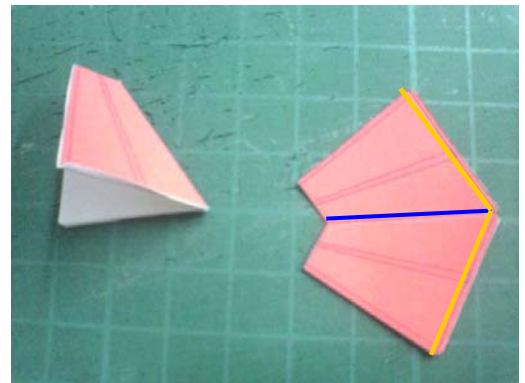

28. 水平尾翼をつける。
Glue the horizontal stabilizer.

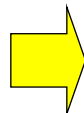
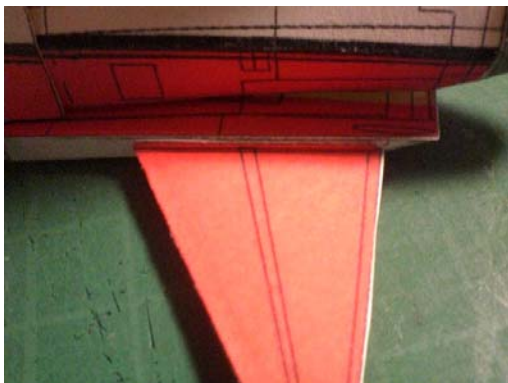

29. H:エアインテークバーンを組み立てて付ける
Fold and glue the H:Air intake vane



完成！

あとは調整して、飛ばしてみてください。感想をお待ちしています。

Finish! Let's fly this paper plane after checking the body and the wing.

Please report on the impression with mail.

F-20 TIGER SHARK

ver0.1 2006.12.17 ojimak_01@yahoo.co.jp